

Summer Math Packet

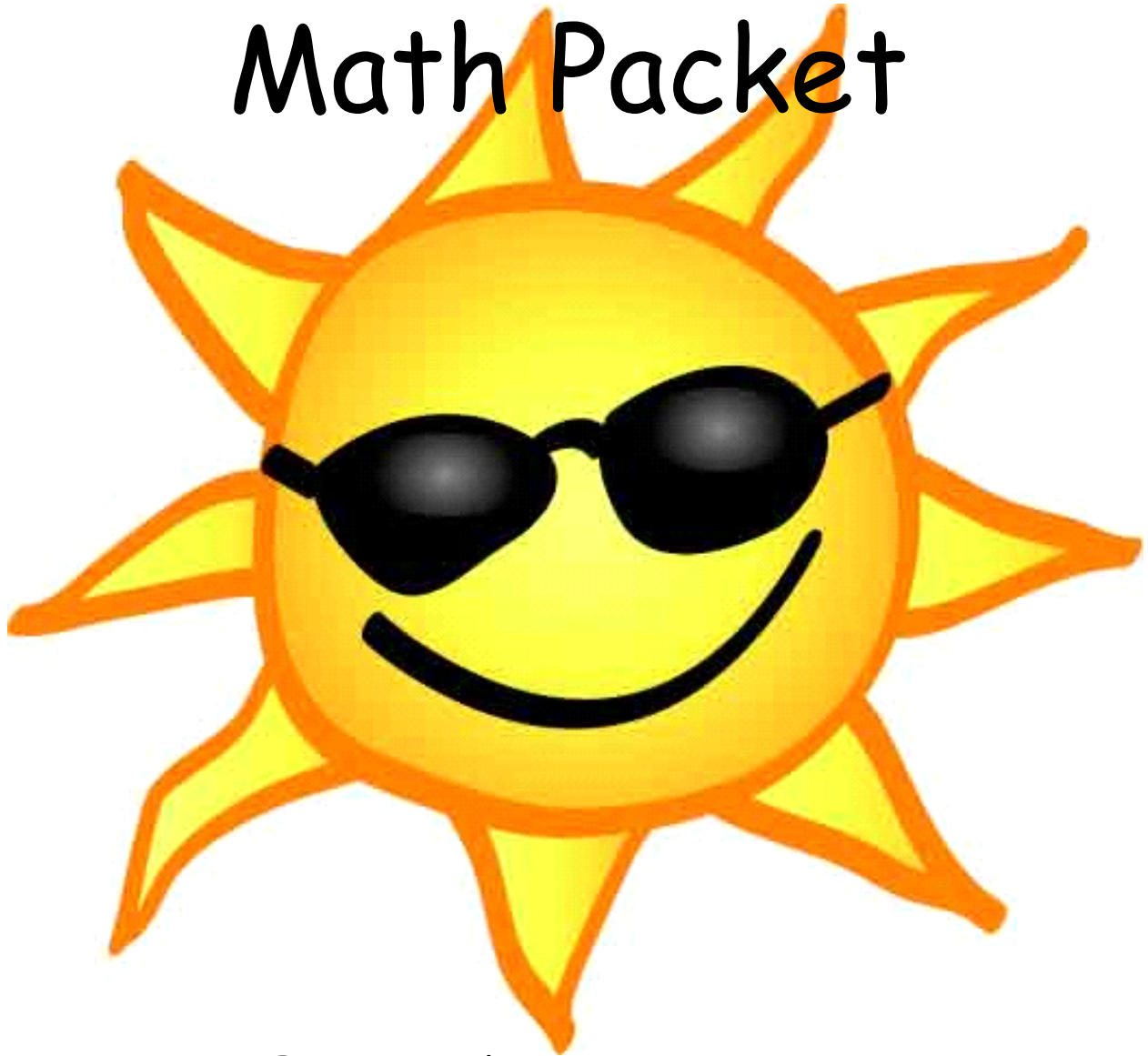

For students entering:

Math 6

Name: _____

Concepts students should know before entering 6th Grade Transition/Math 6:

Students should be advanced at these concepts:

Directions: Complete the following problems. NO CALCULATOR!

$$\begin{array}{r} 19 \\ 4 \overline{)76} \\ \underline{-4} \\ 36 \\ \underline{-36} \\ 0 \end{array}$$

$$2 \overline{)42}$$

$$10 \overline{)110}$$

$$12 \overline{)132}$$

$$8 \overline{)16}$$

$$2 \overline{)80}$$

$$9 \overline{)36}$$

$$6 \overline{)42}$$

$$2 \overline{)144}$$

$$2 \overline{)114}$$

$$2 \overline{)70}$$

$$6 \overline{)102}$$

Order of Operation

Directions: Simplify the following. Remember your PEMDAS rules!

PEMDAS Rules

Evaluate the problem in the following order:

- 1) P - Parentheses
- 2) E - Exponents (Powers and Square Roots)
- 3) MD - Multiplication and Division (Left to Right)
- 4) AS - Addition and Subtraction (Left to Right)

You can remember the order by saying :

Please Excuse My Dear Aunt Sally

a	x	u	i	d	u
r	p	l	v	d	b
e	o	t	i	i	t
n	n	i	s	t	r
t	e	p	i	i	a
h	n	l	o	o	c
e	t	i	n	n	t
s	s	c			i
e		a			o
s		t			n
		i			
		o			
		n			

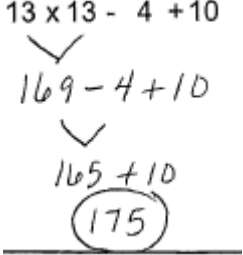
$13 \times 13 - 4 + 10$ 	1. $18 - 11 + 19 \times 3$
2. $24 \div 8 \times 11 + 3$	3. $2 + 11 \times 17 - 12$
4. $9 + 4 \times 12 + 15$	5. $16 \times 3 - 2 + 3$
6. $16 + 9 - 10 \div 5$	7. $16 \div 2 + 19 - 16$

Mixed Numbers & Improper Fractions

Directions: Convert the following improper fractions to mixed numbers. Write your answer on the line next to each problem.

1) $\frac{9}{4} = \underline{\quad 2\frac{1}{4} \quad}$	6) $\frac{11}{5} = \underline{\quad}$	11) $\frac{71}{10} = \underline{\quad}$
2) $\frac{82}{9} = \underline{\quad}$	7) $\frac{61}{6} = \underline{\quad}$	12) $\frac{29}{7} = \underline{\quad}$
3) $\frac{31}{5} = \underline{\quad}$	8) $\frac{7}{3} = \underline{\quad}$	13) $\frac{55}{6} = \underline{\quad}$
4) $\frac{13}{3} = \underline{\quad}$	9) $\frac{50}{7} = \underline{\quad}$	14) $\frac{21}{10} = \underline{\quad}$
5) $\frac{29}{7} = \underline{\quad}$	10) $\frac{17}{4} = \underline{\quad}$	15) $\frac{25}{4} = \underline{\quad}$

Directions: Convert the following improper fractions to mixed numbers. Write your answer on the line next to each problem.

1) $5\frac{1}{3} = \frac{16}{3}$	6) $2\frac{1}{2} = \underline{\quad}$	11) $9\frac{1}{5} = \underline{\quad}$
2) $2\frac{1}{8} = \underline{\quad}$	7) $3\frac{1}{4} = \underline{\quad}$	12) $6\frac{1}{2} = \underline{\quad}$
3) $3\frac{1}{4} = \underline{\quad}$	8) $6\frac{1}{10} = \underline{\quad}$	13) $5\frac{4}{9} = \underline{\quad}$
4) $3\frac{2}{9} = \underline{\quad}$	9) $5\frac{7}{10} = \underline{\quad}$	14) $9\frac{2}{3} = \underline{\quad}$
5) $9\frac{3}{8} = \underline{\quad}$	10) $9\frac{1}{2} = \underline{\quad}$	15) $2\frac{3}{8} = \underline{\quad}$

Long Division

Directions: Complete the following problems. NO CALCULATOR! SHOW ALL WORK!!

<p>1.</p> $\begin{array}{r} 619 \\ 5 \overline{)3,095} \\ \underline{-30} \\ 09 \\ \underline{-5} \\ 45 \\ \underline{-45} \\ 0 \end{array}$	<p>2.</p> $3 \overline{)1,530}$	<p>3.</p> $12 \overline{)6,036}$
<p>4.</p> $9 \overline{)4,581}$	<p>5.</p> $7 \overline{)5,425}$	<p>6.</p> $8 \overline{)7,424}$
<p>7.</p> $3 \overline{)2,424}$	<p>8.</p> $11 \overline{)2,288}$	<p>9.</p> $6 \overline{)5,442}$
<p>10.</p> $8 \overline{)5,656}$	<p>11.</p> $3 \overline{)1,560}$	<p>12.</p> $4 \overline{)3,204}$

Coordinate System

Directions: Write the point that is located at each ordered pair.

1) $(6, 2)$ _____ 2) $(6, 8)$ _____

3) $(10, 1)$ _____ 4) $(4, 5)$ _____

5) $(9, 7)$ _____ 6) $(2, 3)$ _____

7) $(1, 6)$ _____ 8) $(5, 7)$ _____

9) $(2, 1)$ _____ 10) $(7, 4)$ _____

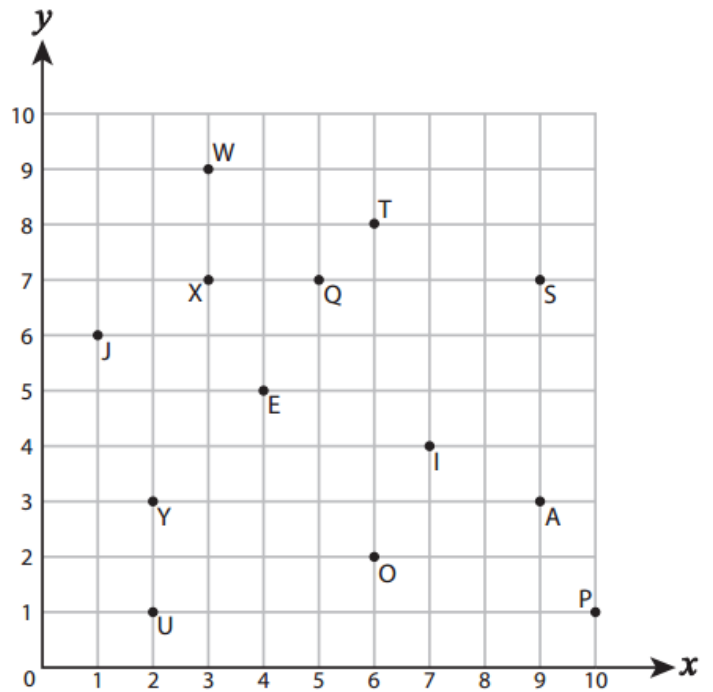

Directions: Write the ordered pair for each point.

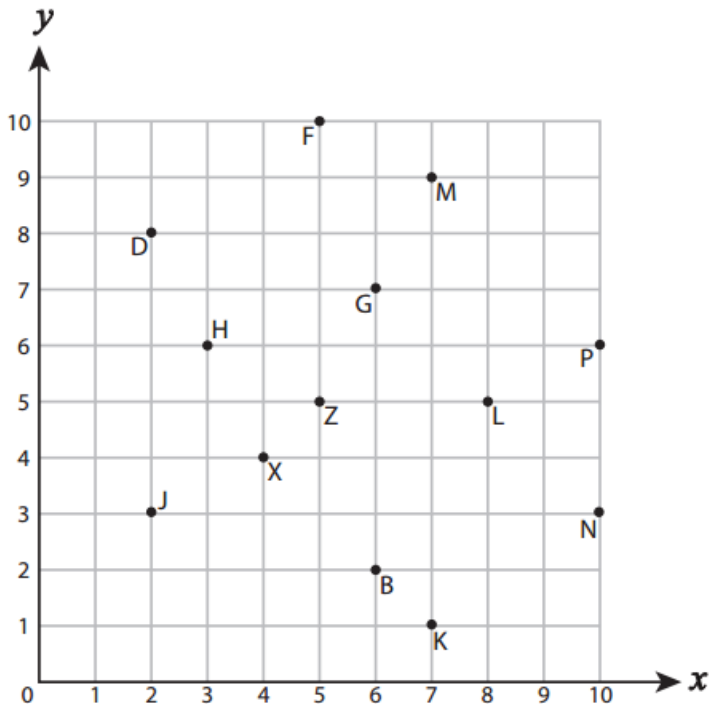

11) N (_____ , _____)

12) X (_____ , _____)

13) B (_____ , _____)

14) L (_____ , _____)

15) Z (_____ , _____)

16) P (_____ , _____)

17) D (_____ , _____)

18) M (_____ , _____)

19) J (_____ , _____)

20) H (_____ , _____)

Directions: Express each fraction as a percent.

$\frac{38}{100} = \underline{38}\%$	$\frac{92}{100} = \underline{\quad}\%$	$\frac{7}{100} = \underline{\quad}\%$
$\frac{12}{100} = \underline{\quad}\%$	$\frac{4}{10} = \underline{\quad}\%$	$\frac{6}{10} = \underline{\quad}\%$

Directions: Express each decimal as a percent.

$0.15 = \frac{\boxed{15}}{100}$ $= \underline{15}\%$	$0.28 = \frac{\boxed{\quad}}{100}$ $= \underline{\quad}\%$	$0.07 = \underline{\quad}\%$
$0.01 = \underline{\quad}\%$	$0.08 = \underline{\quad}\%$	$0.5 = \underline{\quad}\%$
$0.9 = \underline{\quad}\%$	$0.8 = \underline{\quad}\%$	

Directions: Express each percent as a fraction with a denominator of 100.

$53\% = \frac{\boxed{53}}{100}$	$7\% = \frac{\boxed{\quad}}{100}$	$13\% = \boxed{\quad}$
$31\% = \boxed{\quad}$	$5\% = \boxed{\quad}$	$79\% = \boxed{\quad}$

Directions: Determine the prime factorization of the following numbers.

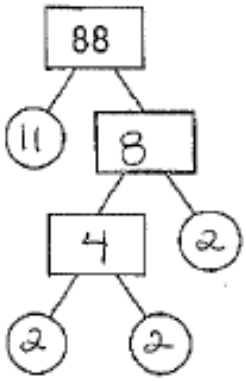
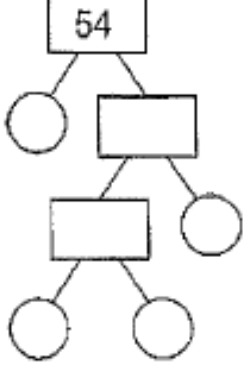
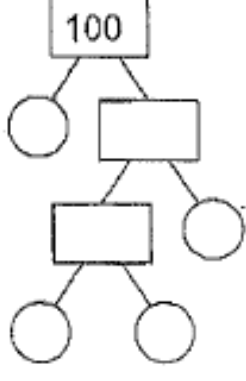
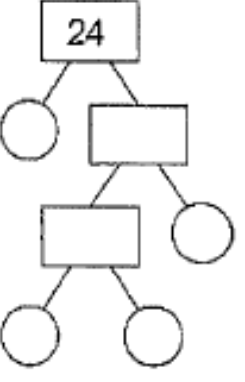
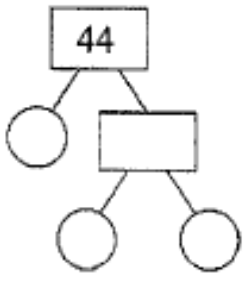
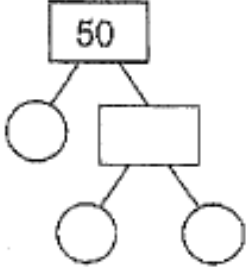
<p>)</p>  <p>Prime Factors $2 \times 2 \times 2 \times 11 = 88$</p>	<p>)</p>  <p>Prime Factors $_ \times _ \times _ = 54$</p>	<p>)</p>  <p>Prime Factors $_ \times _ \times _ = 100$</p>
 <p>Prime Factors $_ \times _ \times _ = 24$</p>	 <p>Prime Factors $_ \times _ = 44$</p>	 <p>Prime Factors $_ \times _ = 50$</p>

Directions: Evaluate the following. You may use a calculator.

$(3)^3 = (3)(3)(3) = 27$	$(1)^3 =$	$(4)^3 =$
$(5)^2 =$	$(2)^3 =$	$(11)^2 =$
$(7)^2 =$	$(6)^3 =$	$(9)^2 =$

Adding & Subtracting Decimals

Directions: Solve the following. DO NOT USE A CALCULATOR!!

Example 1 Add Decimals

Find the value of $3.9 + 2.45$.

STEP 1 Rewrite the problem vertically in order to align the decimal points in each number. Add a zero to 3.9 as a placeholder.

$$\begin{array}{r} 3.90 \\ + 2.45 \\ \hline \end{array}$$

STEP 2 Begin by adding the digits in the hundredths place.

$$\begin{array}{r} 3.90 \\ + 2.45 \\ \hline 5 \end{array}$$

STEP 3 Add the digits in the tenths place. Since $9 + 4 = 13$, regroup 10 tenths as 1 one.

$$\begin{array}{r} 1 \\ 3.90 \\ + 2.45 \\ \hline 35 \end{array}$$

STEP 4 Place the decimal point in the answer. Add the digits in the ones place.

$$\begin{array}{r} 1 \\ 3.90 \\ + 2.45 \\ \hline 6.35 \end{array}$$

$3.9 + 2.45 = 6.35$

Example 2 Subtract Decimals

Find the value of $8.6 - 4.55$.

STEP 1 Rewrite the problem vertically in order to align the decimal points in each number. Add a zero to 8.6 as a placeholder.

$$\begin{array}{r} 8.60 \\ - 4.55 \\ \hline \end{array}$$

STEP 2 Begin by subtracting the digits in the hundredths place. Regroup 1 tenth as 10 hundredths so that you can subtract.

$$\begin{array}{r} 5 \text{ } 10 \\ 8.60 \\ - 4.55 \\ \hline 5 \end{array}$$

STEP 3 Subtract the digits in the tenths place.

$$\begin{array}{r} 5 \text{ } 10 \\ 8.60 \\ - 4.55 \\ \hline 05 \end{array}$$

STEP 4 Place the decimal point in the answer. Subtract the digits in the ones place.

$$\begin{array}{r} 5 \text{ } 10 \\ 8.60 \\ - 4.55 \\ \hline 4.05 \end{array}$$



$8.6 - 4.55 = 4.05$

1. $4.59 + 1.02$	2. $9.04 - 6.32$	3. $5.8 + 0.26$
4. $6.5 - 3.7$	5. $0.4 + 8.61$	6. $3.28 - 1.09$
7. $5.7 + 4.63$	8. $6.3 - 2.99$	9. $8.07 + 0.86$
10. $7.2 - 5.98$	11. $7.02 + 7.3$	12. $5.33 - 2.68$

Finding Area & Perimeter of Rectangles

*Directions: Find the **perimeter** & **area** of the shapes below. All work must be shown!! Please follow the example problems for work we expect.*

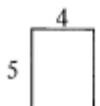
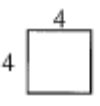
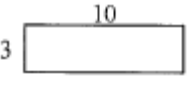
Coordinate Plane

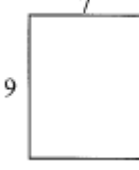
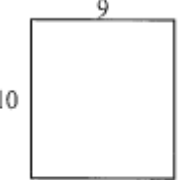
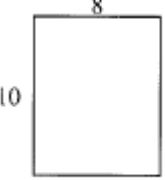
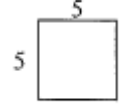
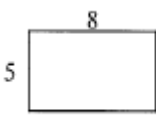
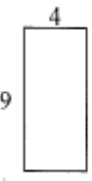
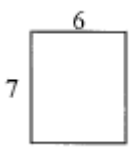
 $A = bh$ $A = 4(5)$ $A = 20 \text{ u}^2$ $P = 2b + 2h$ $P = 2(4) + 2(5)$ $P = 8 + 10$ $P = 18 \text{ u}$	 $A = s^2$ $A = 4^2$ $A = 16 \text{ u}^2$ $P = 4s$ $P = 4(4)$ $P = 16 \text{ u}$	
		
		
		

Directions: Write the point that is located at each coordinate plane.

(1)

- | | |
|-------------------|-------------------|
| 1) (4, 1) _____ | 2) (3, -5) _____ |
| 3) (-5, 1) _____ | 4) (5, 5) _____ |
| 5) (1, -4) _____ | 6) (-1, -5) _____ |
| 7) (-3, -3) _____ | 8) (-5, -2) _____ |
| 9) (-2, 1) _____ | 10) (1, 2) _____ |

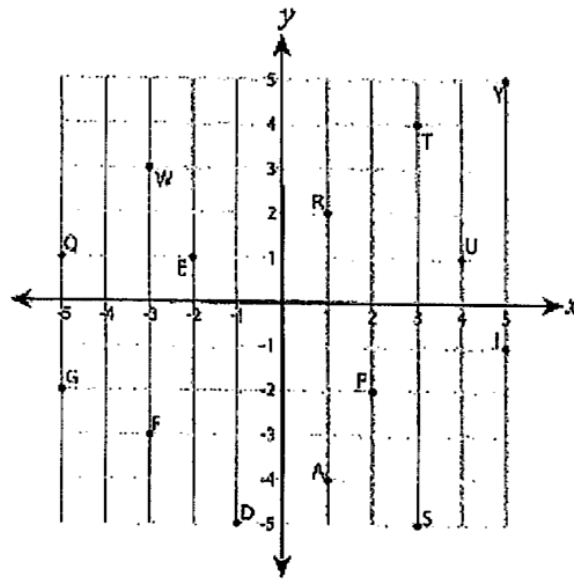

Directions: Write the ordered pair for each point.

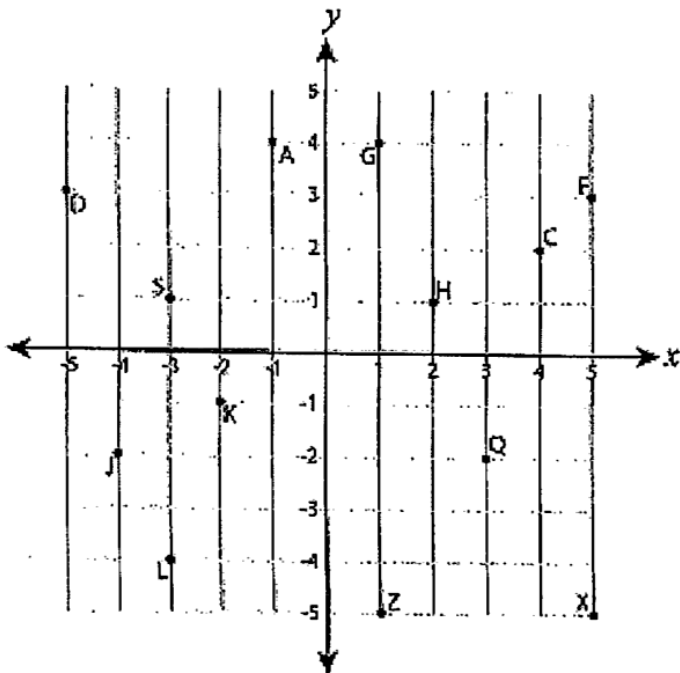

- | | |
|--------------------|--------------------|
| 11) Q (____, ____) | 12) S (____, ____) |
| 13) D (____, ____) | 14) L (____, ____) |
| 15) G (____, ____) | 16) Z (____, ____) |
| 17) X (____, ____) | 18) A (____, ____) |
| 19) J (____, ____) | 20) F (____, ____) |

Directions: Simplify the following fractions.

$\frac{4}{6} = \frac{2}{3}$	$\frac{2}{10} = \frac{\quad}{\quad}$ $\frac{21}{28} = \frac{\quad}{\quad}$	$\frac{10}{15} = \frac{\quad}{\quad}$ $\frac{6}{18} = \frac{\quad}{\quad}$
$\frac{4}{8} = \frac{\quad}{\quad}$	$\frac{16}{20} = \frac{\quad}{\quad}$ $\frac{7}{14} = \frac{\quad}{\quad}$	$\frac{6}{15} = \frac{\quad}{\quad}$ $\frac{12}{20} = \frac{\quad}{\quad}$

Adding Fractions

Directions: Solve the following problems. **NO CALCULATOR!** Put your answers in simplified form.

1. $\frac{4}{7} + \frac{10}{21} =$ $\frac{12}{21} + \frac{10}{21} = \frac{22}{21} = 1\frac{1}{21}$	2. $\frac{8}{9} + \frac{1}{3} =$	3. $\frac{11}{6} + \frac{4}{9} =$
4. $\frac{6}{12} + \frac{12}{4} =$	5. $\frac{4}{5} - \frac{7}{10} =$	6. $\frac{8}{11} + \frac{12}{5} =$
7. $\frac{10}{3} - \frac{2}{12} =$	8. $\frac{11}{6} + \frac{1}{10} =$	9. $\frac{3}{5} - \frac{6}{11} =$

Division Word Problems

Directions: Solve each of the following problems. **NO CALCULATORS!! SHOW ALL WORK!**

<p>1. Oliver played 2 rounds of a trivia game and scored 982 points. If he gained the same number of points each round, how many points did he score per round?</p>	<p>2. Roger has 365 baseball cards in 5 binders. If each binder has the same number of cards, how many cards are in each binder?</p>
<p>3. Chloe had 472 video games. If she placed the games into 8 different stacks, how many games would be in each stack?</p>	<p>4. An ice machine had 480 ice cubes in it. If you were filling up 8 ice chests and each chest got the same number of cubes, how many ice cubes would each chest get?</p>
<p>5. Faye is making bead necklaces. She has 606 beads and is making 2 necklaces with each necklace using the same number of beads. How many beads will each necklace use?</p>	<p>6. There are 545 students in a school. If the school has 5 grades and each grade had the same number of students, how many students were in each grade?</p>

Directions: Solve the following. NO CALCULATORS!! Simplify your answer.

Example: $\frac{2}{3} \times 5 = ?$

make the whole
number a
fraction

$$\frac{5}{1}$$

multiply the
top numbers
(numerators)

$$2 \times 5 = 10$$

multiply the
bottom numbers
(denominators)

$$3 \times 1 = 3$$

write your
result

$$\frac{10}{3}$$

Order of Operation

1. $3 \times \frac{2}{9} =$	$4 \times \frac{3}{15} =$ 2.	$2 \times \frac{9}{19} =$ 3.
$6 \times \frac{3}{24} =$ 4.	$2 \times \frac{2}{5} =$ 5.	$1 \times \frac{5}{5} =$ 6.
$5 \times \frac{1}{7} =$ 7.	$10 \times \frac{1}{16} =$ 8.	9. $3 \times \frac{4}{9} =$
<p>Example: $\frac{4}{5} \times \frac{2}{8} = ?$</p> <p>multiply numerators $4 \times 2 = 8$ reduce final answer multiply denominators $5 \times 8 = 40$ $= \frac{8}{40} = \frac{1}{5}$</p>	$\frac{3}{6} \times \frac{3}{2} =$ 10.	11. $\frac{20}{40} \times \frac{2}{2} =$
$\frac{4}{7} \times \frac{5}{8} =$ 12.	$\frac{2}{6} \times \frac{6}{2} =$ 13.	$\frac{5}{10} \times \frac{2}{1} =$ 14.
$\frac{5}{25} \times \frac{4}{1} =$ 15.	$\frac{15}{17} \times \frac{6}{6} =$ 16.	$\frac{9}{9} \times \frac{1}{1} =$ 17.

Directions: Simplify the following. Remember your PEMDAS rules!

$8 + 4 \times 19 + 10 - 1$ \swarrow $2 \times 19 + 10 - 1$ \swarrow $38 + 10 - 1$ \swarrow $48 - 1$ $\textcircled{47}$	1. $2 \times 17 + 13 \times 3 - 1$
2. $4 - 1 + 16 \times 11 + 8$	3. $4 - 1 + 17 \times 18 \div 9$
4. $18 + 14 \div 2 \times 18 \times 16$	5. $17 \times 14 + 14 - 6 \times 10$
6. $17 \times 10 \div 2 - 1 \times 12$	7. $15 - 13 + 14 \times 9 + 19$
8. $9 \times 5 - 1 + 8 + 15$	9. $18 \times 11 \times 12 \div 3 - 2$

Finding Area of Triangles

Directions: Find the area of the triangles below. All work must be shown. Please follow the example problem for work we expect to see.

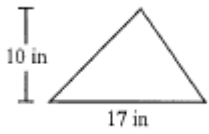

$$A = \frac{1}{2}bh$$

$$A = \frac{1}{2}(17)(10)$$

$$A = 85 \text{ in}^2$$

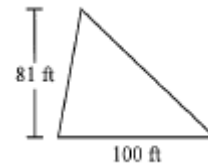
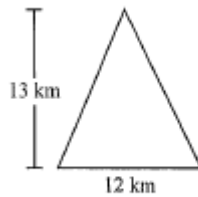
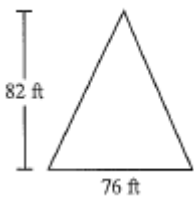
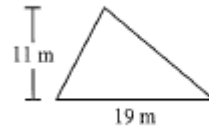
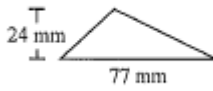
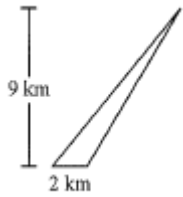
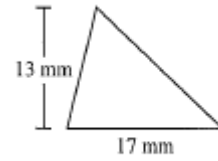
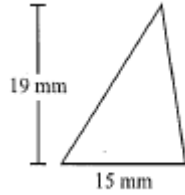

Multiplying Decimals

Directions: Multiply the following.

$1.3 \times 100 = 130$	$6.8 \times 100 =$	$4.196 \times 100 =$
$100 \times 74.3 =$	$46.8 \times 100 =$	$4.68 \times 100 =$
$9.1 \times 100 =$	$3.28 \times 100 =$	$5.095 \times 100 =$

Directions: Multiply the following.

$1.8 \times 1,000 =$	$2.1 \times 1,000 =$	$9.097 \times 1,000 =$
$27.4 \times 1,000 =$	$1,000 \times 10.81 =$	$27.4 \times 1,000 =$

Directions: Complete.

$1.2 = 0.12 \times \underline{10}$ $= 0.012 \times \underline{100}$	$360 = 36 \times \underline{\hspace{2cm}}$ $= 3.6 \times \underline{\hspace{2cm}}$ $= 0.36 \times \underline{\hspace{2cm}}$	$438 = \underline{\hspace{2cm}} \times 10$ $= \underline{\hspace{2cm}} \times 100$ $= \underline{\hspace{2cm}} \times 1,000$
--	---	--

Conversions

Directions: Convert each measurement.

Units of capacity	
8 fluid ounces	1 cup
2 cups	1 pint
2 pints	1 quart
4 quarts	1 gallon

This conversion table shows how to convert ounces, cups pints, quarts, and gallons.

Katya's thermos holds 8 pints.
How many cups does it hold?
 $8 \times 2 = 16$ 16 cups

Hannah's thermos holds 6 cups.
How many pints does it hold?
 $6 \div 2 = 3$ 3 pints

1. 32 fluid ounces _____ cups	2. 6 cups _____ pints	3. 4 quarts _____ pints	4. 16 quarts _____ gallons
5. 16 gallons _____ pints	6. 5 quarts _____ cups	7. 36 cups _____ quarts	8. 72 pints _____ gallons
9. 1 quart _____ fluid ounces	10. 240 fluid ounces _____ pints	11. 7 quarts _____ cups	12. 11 gallons _____ pints

Units of length	
12 inches	1 foot
3 feet	1 yard
5,280 feet	1 mile
1,760 yards	1 mile

This conversion table shows how to convert inches, feet, yards, and miles.

Brian's rope is 60 inches long.
How many feet long is it?
 $60 \div 12 = 5$ 5 feet long

Neilika's rope is 3 yards long.
How many inches long is it?
 $3 \times 3 = 9$ 9 feet long
 $9 \times 12 = 108$ 108 inches long

13. 36 inches _____ feet	14. 6 feet _____ yards	15. 12 feet _____ inches	16. 6 yards _____ feet
17. 4 yards _____ inches	18. 5 yards _____ inches	19. 15,840 feet _____ miles	20. 3,520 yards _____ miles

Convert 25 centimeters to millimeters. Convert 200¢ to dollars.

$25 \times 10 = 250$ mm $200 \div 100 = \$2$

1. 40 cm _____ mm	2. 15 cm _____ mm	3. 30 mm _____ cm	4. 100 mm _____ cm
5. \$35 _____ ¢	6. \$600 _____ ¢	7. 450¢ \$ _____	8. 150¢ \$ _____

Word Problems

Directions: Solve each of the following problems. SHOW ALL WORK!

<p>1. Ned bought 331 pieces of candy to give to 35 of his friends. If he wants to give each friend the same amount, how many pieces would he have left over?</p>	<p>2. An industrial machine can make 245 crayons a day. If each box of crayons has 20 crayons in it, how many full boxes does the machine make a day?</p>
<p>3. A box of computer paper has 1004 sheets left in it. If each printer in a computer lab needed 39 sheets how many printers would the box fill up?</p>	<p>4. Robin had 771 pennies. She wanted to place the pennies into 37 stacks, with the same amount in each stack. How many more pennies would she need so all the stacks would be equal?</p>
<p>5. A builder needed to buy 960 nails for his latest project. If the nails he needs come in boxes of 47, how many boxes will he need to buy?</p>	<p>6. Sarah received 541 dollars for her birthday. Later she found some toys that cost 15 dollars each. How much money would she have left if she bought as many as she could?</p>

Adding Fractions

Directions: Solve the following. NO CALCULATORS!! Show all work and simplify your answer!

Reading a Line Graph

$1\frac{2}{5} + 3\frac{6}{7} = 5\frac{9}{35}$ <hr/> $1\overset{+2}{\underset{\times 5}{\frac{2}{5}}} + 3\overset{+6}{\underset{\times 7}{\frac{6}{7}}}$ <div style="border: 1px solid black; padding: 2px; width: fit-content; margin: 5px auto;">Rewrite as improper fractions</div> <hr/> $\frac{7}{5} \overset{\times 7}{\underset{\times 7}{+}} \frac{27}{7} \overset{\times 5}{\underset{\times 5}{+}}$ <div style="border: 1px solid black; padding: 2px; width: fit-content; margin: 5px auto;">Find least common denominator</div> <hr/> $\frac{49}{35} + \frac{135}{35} = \frac{184}{35} = 5\frac{9}{35}$	$3\frac{1}{4} + 4\frac{1}{2} = \quad 1.$
$2\frac{5}{6} + 5\frac{4}{7} = \quad 2.$	$2\frac{3}{5} + 6\frac{1}{4} = \quad 3.$
$4\frac{2}{3} + 4\frac{1}{6} = \quad 4.$	$3\frac{1}{2} + 3\frac{1}{5} = \quad 5.$
<p>6.</p> $23\frac{1}{2} - 18\frac{1}{6} =$	<p>7.</p> $19\frac{1}{2} - 4\frac{4}{5} =$

Directions: The graph below shows the number of fish caught in a day. Use the graph to answer the questions.

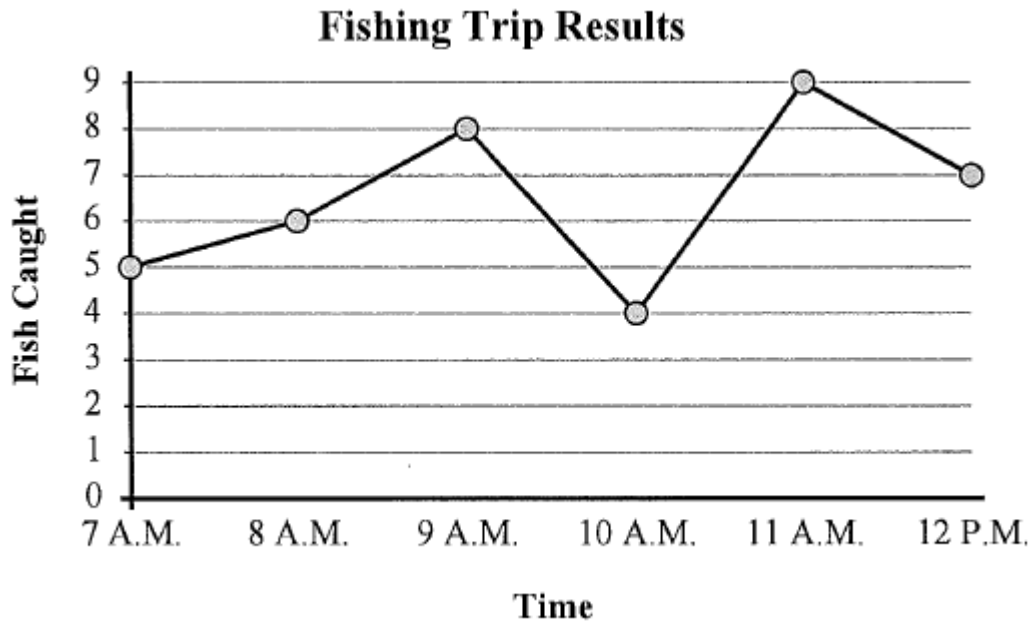

- 1) What time were the most fish caught? _____
- 2) What time were the fewest fish caught? _____
- 3) From 11 A.M. to 12 P.M. did the number of fish caught increase or decrease? _____
- 4) How many fish were caught at 9 A.M.? _____
- 5) How many fish were caught at 10 A.M.? _____
- 6) Were more fish caught at 10 A.M. or 11 A.M.? _____
- 7) Were fewer fish caught at 9 A.M. or 10 A.M.? _____
- 8) What is the difference in the number of fish caught at 9 A.M. and the number caught at 12 P.M.?

- 9) What is the total number of fish caught? _____
- 10) Were there at least 5 caught at 8 A.M.? _____

Squares & Cubes

Directions: Evaluate the following. You may use a calculator.

$(10)^3 = (10)(10)(10) = \boxed{1,000}$		$(12)^2 = (12)(12) = \boxed{144}$	
$(2)^2 =$ 1.		$(9)^3 =$ 2.	
$(4)^2 =$ 4.		$(7)^2 =$ 5.	
$(5)^3 =$ 7.		$(6)^2 =$ 8.	
$(2)^2 =$		$(4)^3 =$ 3.	
$(4)^2 =$		$(12)^3 =$ 6.	
$(5)^3 =$		$(8)^2 =$ 9.	

Directions: Determine the prime factorization of the following numbers.

Example

1)

2)

3)

Directions: Simplify the following. Remember your PEMDAS rules!

$7 \times (5 \times 10 + 4) - 7$ $7 \times (50 + 4) - 7$ $7 \times 54 - 7$ $378 - 7$ $\textcircled{371}$	1. $(8 + 23 - 3) \div (13 - 6)$
2. $(15 - 3) \times (10 + 3) - 4$	3. $(16 + 4) + (11 + 15 \div 5)$
4. $(14 + 29 - 3) \div 20 - 2$	5. $(15 + 18 - 3) \div (15 \times 2)$
6. $(8 + 4) + (10 + 14 \div 7)$	7. $(12 + 22 - 2) + 16 - 2$